

BATTERYstart 300

Jump starters



Engine size compatibility

To jump start 12 V vehicles with up to 6 L petrol engines and 3 L diesel engines



Battery Power

Powerful 13,000 mAh Lithium Cobalt battery



Powerbank-Function

Charging electronic devices including smart phones and tablets



Compact and powerful lithium jump starter with power bank feature

The OSRAM BATTERYstart300 compact Lithium Cobalt LiCoO₂ jump starter for small to medium 12V vehicles up to 6L petrol engines and 3L diesel engines.

Smaller in size than most typical jump starters, the BATTERYstart300 is a compact solution without compromising on power. It includes intelligent safety clamps to keep the jump starter, user and vehicle safe with reverse-polarity, anti-spike and short circuit protection.

Comes with a bright LED light and a power bank feature, which allows you to charge electronic devices on the go – just connect a USB charger and the power bank will kick in.

Product datasheet

Technical data

Product information

Application (Category and Product specific)	Lithium Starter
Efficiency	Better
Recommended Petrol Engine size (up to)	6 l
Recommended Diesel Engine size (up to)	3 l
USB sockets 2.1A	2
12V Power socket connection	n/a

General Product Information

Global order reference	OBSL300
------------------------	---------

Electrical Data

Cranking Amps	300
Peak Amps	1500

Physical Attributes & Dimensions

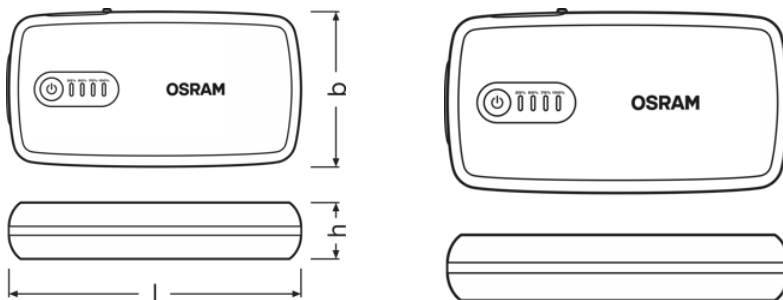

Length	168.0 mm
Width	88.0 mm
Height	33.0 mm

Additional product data

Type of Battery	LiCoO2
Battery Capacity	13000 mA
Charging Type	Micro-USB
Charging time	3 hr
Power bank function	Yes

Product datasheet

Environmental & Regulatory Information





Information according Art. 33 of EU Regulation (EC) 1907/2006 (REACH)	
Candidate list substance 1	Lead
CAS No. of substance 1	7439-92-1
Safe use instruction	The identification of the Candidate List substance is sufficient to allow safe use of the article.
Declaration no. in SCIP database	ada11f03-1c52-4c49-9f3f-4ab9687039c7

Logistical Data

Product code	Product description	Packaging unit (Pieces/Unit)	Dimensions (length x width x height)	Volume	Gross weight
4052899620483	BATTERY start 300	Folding carton box 1	214 mm x 132 mm x 96 mm	2.71 dm ³	848.00 g
4052899620568	BATTERY start 300	Shipping carton box 4	282 mm x 232 mm x 224 mm	14.65 dm ³	3752.00 g

The mentioned product code describes the smallest quantity unit which can be ordered. One shipping unit can contain one or more single products. When placing an order, for the quantity please enter single or multiples of a shipping unit.

Download Data

File	
	User instruction BATTERYstart
	Movie application BatteryStart How to Video (ITA)
	Movie application BatteryStart How to Video (EN)
	Product movie OSRAM BATTERYstart 300 Product Video (EN)

Legal advice

Application advice:

For more detailed application information and graphics please see product datasheet.

Application advice

For more detailed application information and graphics please see product datasheet.

Disclaimer

Subject to change without notice. Errors and omission excepted. Always make sure to use the most recent release.

